

**Item Number**  
RAM-VB-129

**RAM No-Drill™ Seat Bases**  
National Products, Inc.

**Vehicle base for the  
Dodge Magnum (2005-Newer)  
Dodge Charger (2005-Newer)**

**SPECIFICATIONS**

**Placement**

Passenger side on the floor, between seat cushion & seat

**Drilling Required**

No - uses existing seat bolts  
Dodge Magnum (2005-Newer)  
Dodge Charger (2005-Newer)

**Seat Configuration**

Bench

**Pole or Pedestal**

Purchased Separately

**Construction/Finish**

Steel/Black Powdercoat

**Weight**

4.9 lbs.

**Dimensions**

A = 19.375" B = 7.125"  
Hole Center = 16.5"

**Features**

Installs in minutes with no drilling required  
Won't interfere with passenger leg space

**Misc.**

Rock solid construction

Lifetime warranty

National Products, Inc.  
Phone: 206-763-8361  
Fax: 206-763-9615  
Address: 1205 S Orr St  
Seattle, WA 98108  
Website: [www.ram-mount.com](http://www.ram-mount.com)  
Email: [staff@ram-mount.com](mailto:staff@ram-mount.com)



Shown In Use

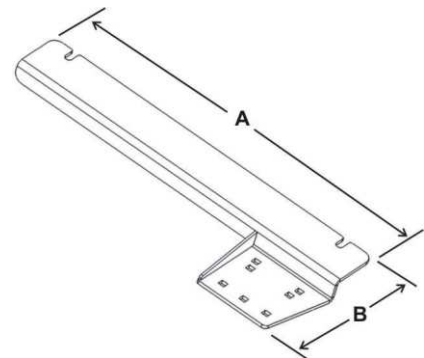

RAM-VB-129



**Item Number**  
RAM-VB-129

**RAM No-Drill™ Seat Bases**  
National Products, Inc.

**Vehicle base for the**  
**Dodge Magnum (2005-Newer)**  
**Dodge Charger (2005-Newer)**

**INSTALLATION INSTRUCTIONS**

1. Loosen the front bolts that hold the seat cushion to the slides. The bolts only need to be loosened enough to so the mount can be slid between the cushion and the slides.
2. Slide the mount between the cushion and the slides and re-tighten the bolts.
3. Move the seat back to the rear most position.

Please Note: If the seat is moved forward, the mounted equipment could possibly hit the dash.

National Products, Inc.  
Phone: 206-763-8361  
Fax: 206-763-9615  
Address: 1205 S Orr St  
Seattle, WA 98108  
Website: [www.ram-mount.com](http://www.ram-mount.com)  
Email: [staff@ram-mount.com](mailto:staff@ram-mount.com)

