

PAGE 1

LIFT

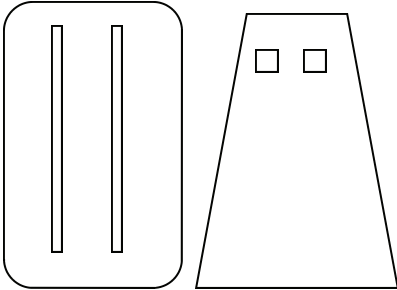

A-Round Holes B-Square Holes

BASE

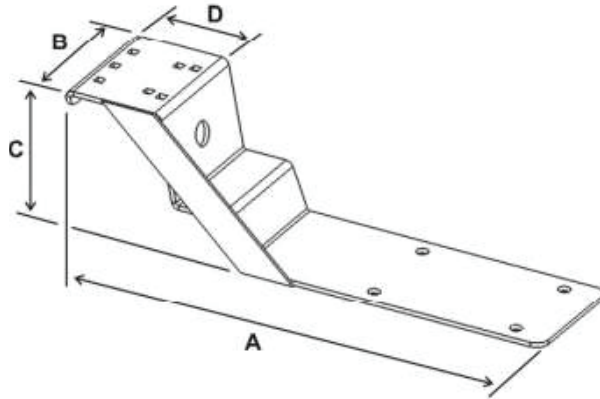

TUBE

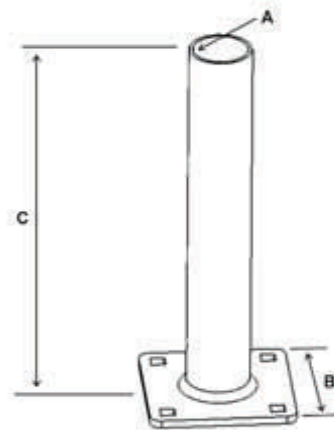

Assembly Instructions:

1. Lift is pre-assembled with nut, bolt and washer.
2. Round holes are lined up underneath base, with front holes of D on base.
3. Curved edges are facing the base.
4. Tube is placed on top of D and the lift and tube are bolted to the base. Place bolts, head side up through tube base, base and lift. Add washer and nut and tighten. Finish mounting tube to base by adding other two bolts in back holes of D on base.
5. Adjust lift by sliding A and B (B pressing on vehicle floor) for maximum support.
6. Follow second page of instructions for mounting base under seat and assembling other base parts.

COMPLETED BASE



Freightliners, Volvos, Kenworth, and other Semi-Truck Makes

Base Assembly-IGNORE ALL PRE-DRILLED HOLES FOR NO DRILL INSTALLATION!!

1. Remove plastic bag containing base and support from the box. The support is made up of 2 pieces. It looks like 2 pieces of metal with an adjustable slot in one piece and bolt hole in the other, attached together with a large nut, bolt, and washer. These pieces provide additional support for the base. When mounting the pole to the base, use the 4 bolts, nuts and washers (provided with the base) to attach the pole and support to the base. Line up the 2 round holes on the support, with the 2 back holes of the base where the pole mounts. Place the nuts on bolts in the holes with the rounded part of the bolt on top and tighten down. Add bottom part to support and extend fully. Now you have the pole and the support on the base.
2. Loosen the 4 seat bolts at the floor. (It is not necessary to remove the four bolts.)
3. Slip the foot of the mount under the passenger seat. Place the base where you want it to stay.
4. Tighten the 4 seat bolts. Now the base is sandwiched between the floor and the bottom of the seat and the support is pressed securely to the floor.

Upper Pole Assembly

5. Remove the parts and instructions from the plastic bag.
6. The upper pole assembly includes assembling the bottom wedges with the spring between the wedges.
7. Screw the nut on the bottom of the all thread bolt to where the threads of the bolt are flush.
8. Place a wedge up and slip it down the all thread until the nut settles correctly in the socket at the bottom.
9. Place the spring over the all thread bold slip it to the bottom.
10. Place the upper wedge facing down towards the bottom wedge, placing the wedges opposite of each other.
11. Place the tube, flange up, over the all thread. Make sure the upper wedge shoulder fits in the tube.

Double Swing Arm Assembly

12. Open the plastic bag with the double swing arms. Notice how the washers are placed over the bolt.
13. Place the large plastic washer over the all thread of the upper pole with the flat side down.
14. Place the arm hole end over the all thread bolt. The arm will fit flush on the plastic washer.
15. Place the flat steel washer over the all thread bolt. Place the washer with ball Bering over the all thread. Then place the other flat steel washer over the all thread. Screw the large hand nut down to just where it touches the washers.
16. Place the upper pole into the lower pole on the base. Snug the hand nut down. Do not over tighten.

Tough Tray Assembly

17. The tough tray assembly is a little tougher. Make sure you read all the instructions carefully. Remove all the parts in the plastic bag and lay them out on a table.
18. When assembling the tough tray, make sure you look carefully at all the parts including the nuts, bolts, and washers. Start the nuts by hand on each bolt to make sure they match.
19. Pull the tough tray apart in 2 pieces. Choose the correct bolts with washers to install the spring first. Drop the nut down from top. (Notice the nuts are locking nuts and have to be turned correctly when dropping in the top of the tough tray. Make sure the fiber part of the nut is facing towards you.) The nuts fit in a socket. They will not turn when tightening the screw heads.
20. After the tray is pulled apart in two pieces, install the bolt with the washer on the end of the larger piece first. Do the same with the smaller side. Do not tighten bolts down. Hook the spring on the larger side bolt under the washer going through the center of the tray.
21. Put the two pieces together and push it all the way in. With your hands, stretch the spring to the smaller side and hook the spring under the washer. Tighten both bolts snugly. Do not over tighten.
22. Remove the ball from the end of the arm. Place the ball on the bottom of the tough tray, lining up all four holes on the ball with the four holes of the tough tray. Note: There are several holes in the ball. There is only one way all four holes will line up. When all holes line, up mark the position. Put a screw through the ball plate into the tray. Turn the screw until the ball is just against the base of the tray. Do the same with the other screws and tighten the screws down.
23. Attach the ball socket on the arm to the ball under the tough tray. Do not over tighten.